

**Series 8, heat pump tumble dryer, 8 kg**  
**WQB235B8AU**

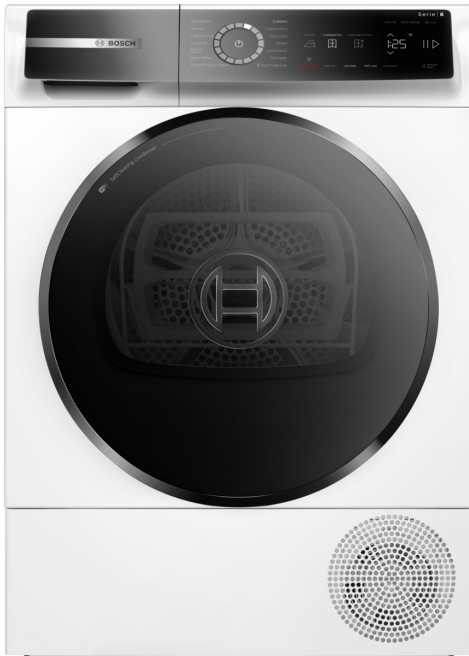

- **Home Connect:** home appliances with smart connectivity for an easier everyday life.
- **Smart Dry:** your connected dryer and washer recommend the right drying programme.
- **ActiveAir Technology reuses existing heat efficiently during the entire drying process.**
- **Self Cleaning Condenser: keeps the condenser free of fluff to maintain optimal energy efficiency.**
- **Bed linen programme with reversible drum: perfect drying results even in mix loads of large and small items.**

Built-in / Free-standing: ..... Free-standing  
 Removable top: ..... No  
 Door hinge: ..... Right reversible  
 Length electrical supply cord: ..... 145.0 cm  
 Dimensions (HxWxD): ..... 842x598x613 mm  
 Net weight: ..... 56.0 kg  
 Fluorinated greenhouse gases: ..... No  
 Hermetically sealed equipment: ..... Yes  
 EAN code: ..... 4242005364084  
 Connection rating: ..... 600 W  
 Fuse protection: ..... 10 A  
 Voltage: ..... 220-240 V  
 Frequency: ..... 50 Hz  
 Capacity: ..... 8.0 kg



- WTZ27500 Stacking kit with pull-out shelf  
 WTZ27510 Stacking kit  
 WTZPW20D Platform with pull-out, dryer, cubic

## Series 8, heat pump tumble dryer, 8 kg WQB235B8AU

### Consumption rates

- 10 stars
- Energy consumption 98 kWh per year on Cottons, Cupboard Dry Plus, Drying level 1, used once per week. When tested in accordance with AS/NZS 2442.2. Actual energy use and running costs will depend on how you use the appliance.

### Capacity

- Capacity: 8 kg

### Design

- Elegant and ergonomically inclined control panel for easy use
- LED interior drum light bathes the inside of the drum in a brilliant white light when opened

### Programs

- standard programmes: cotton, easy care
- Bed Linen Program: reduces tangling of big items thanks to reversible drum
- programmes via app: Time program cold
- Special drying programs:
  - App
  - Cottons, Bed linen programme with reversible drum Shirts/Blouses: designed to allow immediate ironing or hanging up shirts/blouses after the program completes. Cotton Eco Delicates: items made from satin, synthetic or blended fabrics Towels: hard wearing towels and dressing gowns made of cotton Hygiene Plus Mixed: items made from cotton or blended fabrics Super 40': short program for synthetic fabrics and light cottons Sportswear: sports and leisure items made from synthetic fibers, microfiber or fleece Easy Care: items made from synthetic or blended fabrics Wool in basket Timed Program Warm: manually set a custom time for drying slightly damp or multi layered thick items
- Touch control option settings: basic setup, Iron dry, Cupboard dry, Cupboard dry+, Finished in (delayed start): you can delay the start of the program by up to 24 hours, Half load option: optimises the drying settings (load and duration) for small loads., Child lock, Easy Iron: the drum moves the laundry at regular intervals after drying to prevent creasing, My favorite, Control dial with integrated power On/Off button, - Remote Start: allows you to start and control the appliance remotely via the Home Connect app, Low Heat: reduce the drying temperature for delicate fabrics, smartDry/IntelligentDry, Start/Pause the program, 24 h Finished in (delayed start): you can delay the start of the program by up to 24 hours

### Performance

- SelfCleaning Condenser: the condenser automatically cleans itself and does not require any manual cleaning. This also helps to ensure the dryer performs economically with optimal energy efficiency
- Fast Dryer Technology, dries clothes upto 8 minutes per kilogram faster than other Bosch heat pump dryers
- Sensitive drying system: textile friendly drum design and SoftFlow paddles ensure soft, fluffy laundry and helps to reduce creasing
- ActiveAir heat pump technology, existing heat is reused efficiently during the entire drying process
- Anti crease cycle 120 min at the end of the program
- Half Load option: optimizes drying for smaller loads

### Features

- Home Connect: Smart Start, Remote Monitoring and Control, Smart Dry, Remote Diagnostics, Onboarding, Programme Assistant, further programmes via download, Always keep your appliance up to date via firmware update.
- right-hinged, reversible
- SmartDry: Perfect drying programme based on last washing cycle
- load recommendation
- 2 time-based programs
- 7 Sensor-Care plus 2 time-based programs
- AntiVibration design: for greater stability and quietness
- Ultimate woolCare system with drying basket
- Large water condensation container: If there is no drain hose connected to the appliance the condensation water from the drying cycle will be stored in the condensation container
- Glass door with 180 ° opening angle
- Time delay to select end of time of your wash (1-24 hours) and time remaining indicator

### Technical Information

- Dimensions (H x W x D): 84.2 cm x 59.8 cm x 61.3 cm (65.1 cm including door handle)
- Slide-under height of 85cm
- Operating noise level: 61 dB(A)

### Display Screen & Alerts

- Consumption Indication: Information about energy consumption
- End of cycle indicator

### Safety

- Child safety control lock

**Series 8, heat pump tumble dryer, 8  
kg  
WQB235B8AU**

Measurements in mm

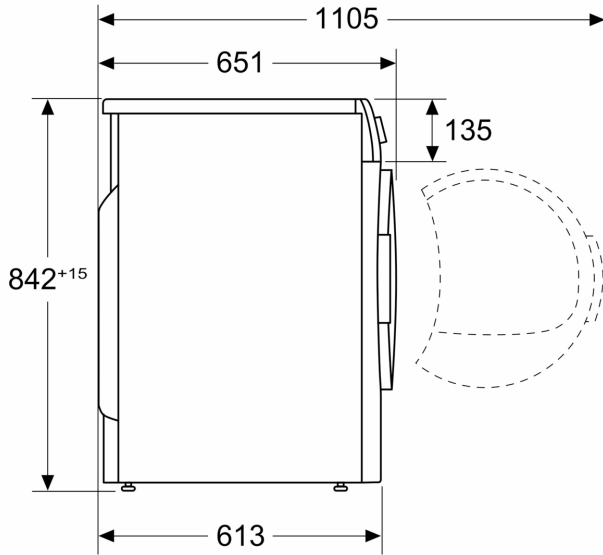

Measurements in mm

