

90cm Series 7 Integrated Insert Wall Rangehood, External Motor

Series 7 | Integrated

Stainless Steel and Glass



This integrated insert rangehood has an externally installed inline motor to deliver near silent yet powerful extraction of steam, grease and cooking odours.

- With three fan speeds plus a boost function, select the perfect extraction rate for your cooking
- External motor delivers near silent operation in the kitchen
- Powerful maximum air movement of 1200m³/hr

- Wi-Fi enabled for notifications through the SmartHQ™ app

DIMENSIONS

Height	316 mm
Width	830 mm
Depth	280 mm

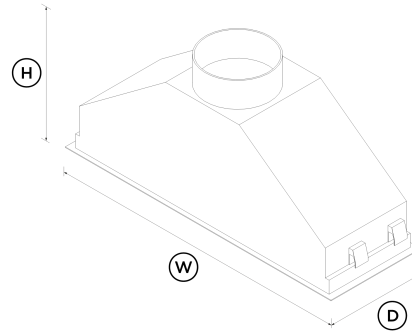

FEATURES & BENEFITS

Near Silent Extraction

The powerful external motor is installed outside the home to deliver near silent extraction of cooking odours and steam from the kitchen.

Seamless Integration

This rangehood can be built into your cabinetry for a seamless look. A black glass control panel and stainless steel finish are designed to match the rest of Fisher & Paykel's kitchen appliance family.

Effective Extraction

This rangehood features three fan speeds plus boost function, providing powerful extraction to quickly remove odours and steam. As odours can linger in the kitchen well after cooking is finished, the timer keeps the rangehood working for up to 15 minutes before automatically turning off.

Full Surface Lighting

Energy-efficient, dimmable LED lights provide superb illumination over the entire cooking surface.

Easy Cleaning

Designed for simple removal, the filters are easy to clean and dishwasher safe, while the glass and stainless steel finish is easily wiped clean. The SmartHQ™ app will notify you when to clean the filters to ensure you get the best performance out of your rangehood.

Considered Efficiency

The right amount of air is extracted to effectively remove cooking odours with reduced effect on your heating or air conditioning.

SPECIFICATIONS

Accessories (included)

Aluminium filter	792943
External motor kit	50170 HB 1200E* (included)

Accessories (sold separately)

Extra ducting length	792961
Light bulb	requires service to replace

Height	316 mm
Width	830 mm

[↓](#) User Guide Integrated Insert Rangehood

Fan ratings

Maximum air movement	1200 m ³ /hr
----------------------	-------------------------

Product information

Control type	Capacitive touch
--------------	------------------

Where applicable:

All appliances use energy, and energy usage typically generates carbon emissions. **Fisher & Paykel Appliances' In-use Energy Carbon Emissions Estimate** indicates carbon emissions from a product's in-use energy. This is calculated either annually or per cycle, using the product's market-specific energy label energy consumption data multiplied by the carbon emissions factor for energy in your country or region.

Our In-use Energy Carbon Emissions Estimate is designed to assist customers in making informed purchasing decisions when comparing different Fisher & Paykel products. For example, a heat pump dryer typically has a lower In-use Energy Carbon Emissions Estimate than a vented dryer.

Installation and cleaning

Air outlet size	200 mm
Dishwasher safe filters	2
Ducted	Top extraction

Ventilation features

Auto-off/Run-on timer	•
Dimmable lights	•
Filter cleaning alert	•
Light type	LED strip
Timer function	•

Performance

Extraction type	Perimeter
Fan speeds	4
Fan speeds + boost	•
Filter type	Mesh with perimeter extraction
Number of filters	2

SKU	50192
-----	-------



A PEACE OF MIND SALE
 24 Hours 7 Days a Week Customer Support
 T 1300 650 590 W www.fisherpaykel.com

The product dimensions and specifications in this page apply to the specific product and model. Under our policy of continuous improvement, these dimensions and specifications may change at any time. You should therefore check with Fisher & Paykel's Customer Care Centre to ensure this page correctly describes the model currently available. © Fisher & Paykel Appliances Ltd 2020

Power requirements

Supply frequency	50 Hz
Supply voltage	240 V

Other product downloads available at fisherpaykel.com

- [↓](#) 2D-DWG Insert Rangehood
- [↓](#) 2D-DXF Insert Rangehood
- [↓](#) Data Sheet Insert Rangehood
- [↓](#) Service & Warranty
- [↓](#) Installation Guide Integrated Insert Rangehood

Product dimensions

Depth	280 mm
-------	--------