

169 Bottle Wine Cabinet Dual Zone

SERIES

Contemporary

AESTHETICS

Black Powder Coated Finish

Black Tinted, UV Triple Glazed Door

FUNCTIONALITY

Dual Temperature Sensor

Compressor Motor

Digital Control Panel

Tropical Rated

Ambient Temp. up to 43°C

2 × Internal LED Lights (fade-in / -out)

Zero Clearance Hinge

50-80% Humidity Control

Anti-vibration

Reversible Door

Child Lock Safety

Unique Lock System (10 Kinds)

STORAGE CAPACITY

Bottle Capacity 169 Bottles

Total Capacity 430L

TEMPERATURE RANGE

Upper Zone 4°C to 18°C

Lower Zone 8°C to 22°C

ACCESSORIES

14 × Timber Shelves (Beech)

Including 5 × Telescopic Runners

Including 1 × Display Shelf

CLEANING

Easy to Clean Exterior

Easy to Clean Glass Doors

Automatic Defrost

MAX NOISE LEVEL

Quiet 39 dB(A) Operation

WEIGHT (KG)

Net: 96kg

Gross: 114kg

SIZE, W/D/H (MM)

Packaged: 654 × 764 × 1815

Physical: 595 × 680 × 1788

INSTALLATION

Built-in or Freestanding

Door Open Angle: 115°

Door Open Width: 840 mm

Top Clearance Minimum 2.5cm

Side Clearance 0-5mm

POWER REQUIREMENTS

Power Connection 10 Amp, Plug

Rated Voltage 220-240V / 50Hz

Power Consumption 0.953 Wh/24h

ADDITIONAL DETAILS

Barcode 9349260095311

Warranty 3 Years

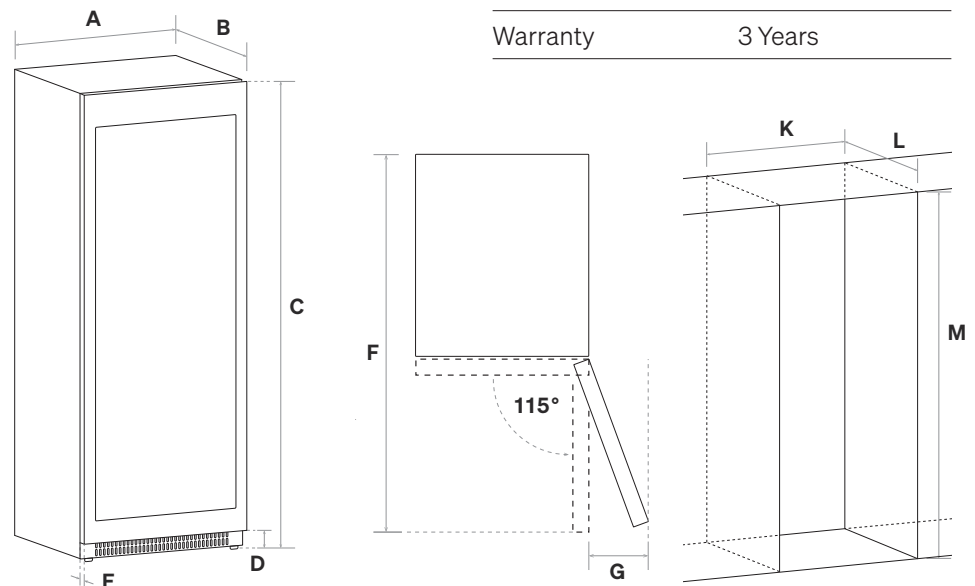

FRONT VIEW

Note: See the user manual for detailed ventilation and installation details

DIMENSIONS (MM)

A 595	C 1788-1848	E 48	G 245	L 680
B 680	D 83	F 1291	K 595-600	M 1813-1889