

# Silverdale

AUSH.4861

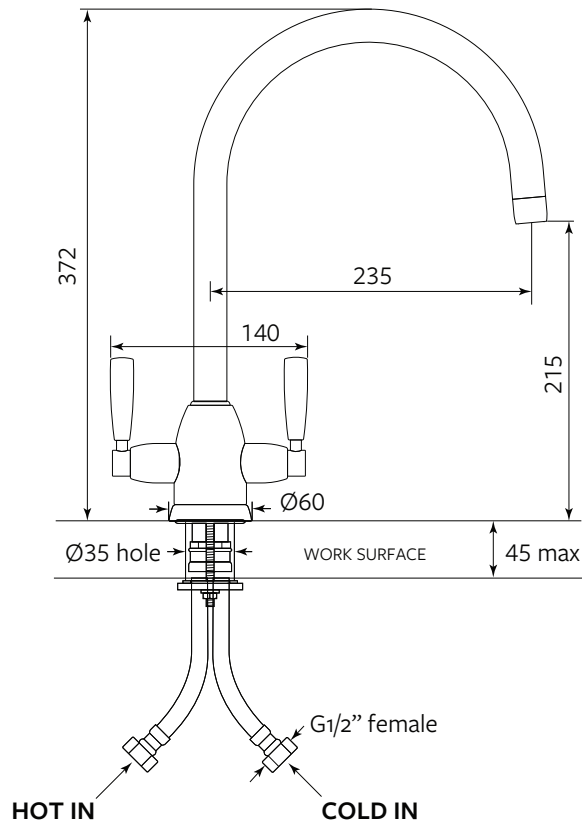

MODEL	CODE
Silverdale - Chrome	AUSH.4861CP
Silverdale - Nickel	AUSH.4861NI
Silverdale - Pewter	AUSH.4861PF
Silverdale - English Bronze	AUSH.4861EB
Silverdale - Satin Brass	AUSH.4861SB
Silverdale - Polished Brass	AUSH.4861BR
Silverdale - Gold	AUSH.4861IG

*Also Available: Silverdale with Spray Rinse (AUSH.4866) Please note, spray rinse cannot be added to the standard mixer later.*

**Features include:**

- Handcrafted in the United Kingdom using DZR brass
- Metal lever handles with engraved temperature indicators
- 1/4 turn German ceramic disc flow control
- Vernier insert for accurate handle alignment
- 15 Year warranty. Please visit our website for individual finish warranties

Temperature range: Min 1°C. Max 70°C  
 Working Pressure: Min 1 Bar/15psi. Max 5 Bar/75psi  
 Packed Weight: 2.99kg  
 Flow Rates: 1 Bar: 8.2L/min  
 2 Bar: 11.4L/min  
 3 Bar: 14.4L/min

